

## SPECIFICATIONS:

CS2 WATER-TIGHT CORD SEAL - U L Listed seal is designed for use with 10/3 type "ST" submersible cable and has 3/4" MPT connection. Cord seal is U.L. listed for use with Hall Fountains junction boxes.

## PARTS LIST:

ITEM	QTY.	DESCRIPTION
①	1	CORD SEAL BODY TYPE 544 PHOSPHOR BRONZE
②	1	CORD SEAL NUT TYPE 544 PHOSPHOR BRONZE
③	1	CORD SEAL GROMMET NEOPRENE
④	1	CORD SEAL GROMMET WASHER DELRIN

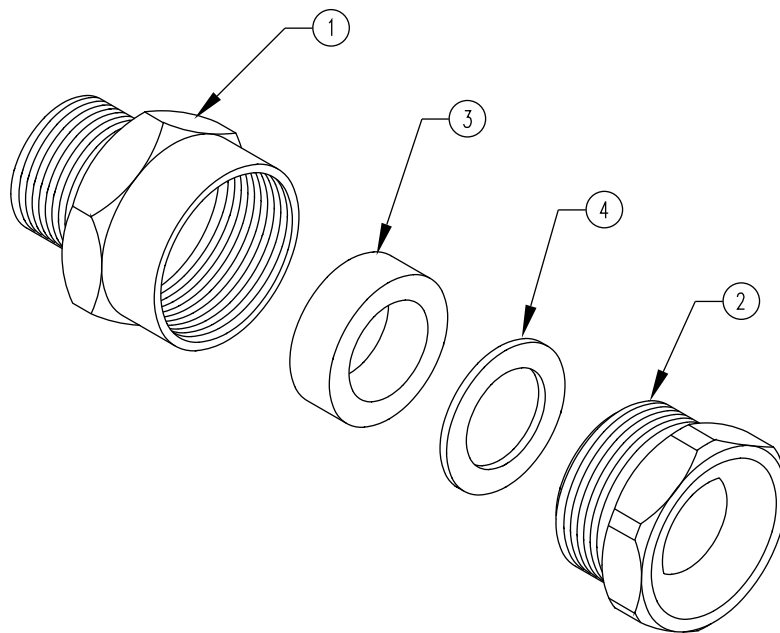

### WARNING!

#### ELECTRICAL SHOCK HAZARD

HALL FOUNTAINS, INC. STRIVES TO MANUFACTURE FOUNTAIN EQUIPMENT OF THE HIGHEST QUALITY POSSIBLE, BUT IS STILL CONCERNED WITH THE FACT THAT WATER AND ELECTRICITY CAN CONSTITUTE A POTENTIAL ELECTRICAL SHOCK HAZARD.

FOUNTAIN ELECTRICAL EQUIPMENT MUST BE INSTALLED BY QUALIFIED KNOWLEDGEABLE PEOPLE WITH THE UTMOST OF CARE AND IN STRICT ACCORDANCE WITH ARTICLE 680 OF THE NATIONAL ELECTRICAL CODE AND ANY OVERRIDING LOCAL CODES THAT MAY APPLY.



# CS2 Watertight Cord Seal

5500 N.W.22 AVE. FT. LAUDERDALE, FL 33309

PHONE: 1-800-777-4255 \* 1-954-484-8530