

SPECIFICATION: TR40 SAND FILTER WITH MULTIPOINT VALVE – features seamless fiberglass construction. Total filter area is 4.9 square feet and flow rate capacity is 100 gallons per minute. Comes complete with top mounted pressure gauge protected from "water hammer" with clear sight glass and air relief valve. Also included is a six position multiport valve for easy backwashing with 2" female pipe thread inlets. Filter sand is not supplied to avoid additional shipping weight and possible damage during transit. At system "start up" the TR100 requires 575 lbs. of filter sand media. (see chart below).

FILTER DATA						
Filter Area	Filter Rate	6 Hour Turnover	8 Hour Turnover	10 Hour Turnover	Sand Required (in pounds)	Sand Size
4.9 sq.ft.	100 GPM	36,000 G	48,000 G	60,000 G	575	.018-.022 in.

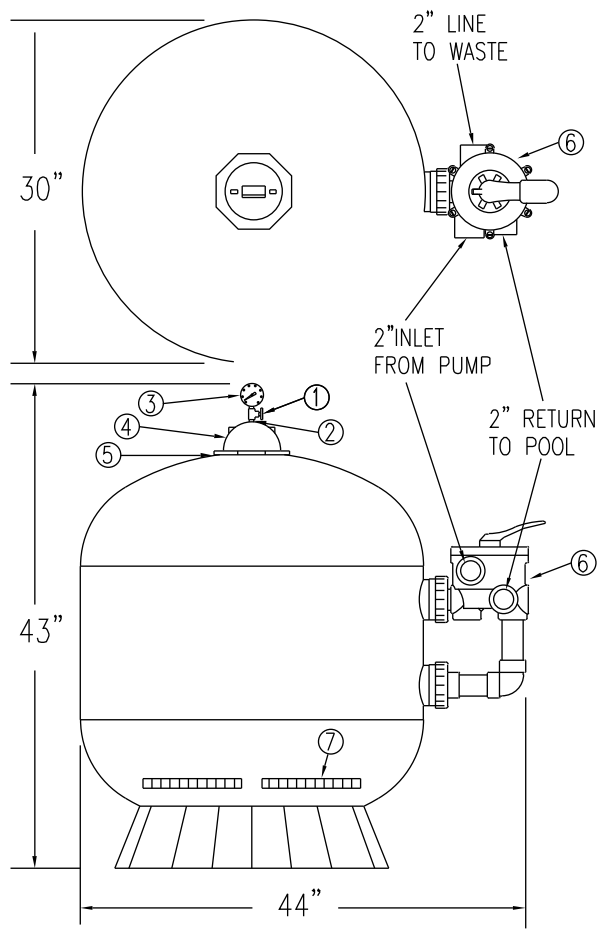

BACKWASHING FILTER

To perform the backwash operation, first shut off pump. Shift the valve handle to the backwash position. (Position of valve handle is changed by first pushing down and then rotating to desired location.) Start pump. The unit should backwash until the water appears clean thru the transparent closure dome. The backwash operation takes about two or three minutes. Stop the pump, and shift valve handle to the rinse position. Start pump and run for approximately 30 seconds. Stop the pump and turn valve handle to the filter position. Start pump, unit has now started a new filtering cycle.

PARTS LIST

- ① Air bleeder / tee assembly
- ② Tee adapter
- ③ Pressure gauge
- ④ Sight glass dome
- ⑤ Sight glass O-ring
- ⑥ Multi-port valve assembly
- ⑦ Lateral assembly



TR100
Fiberglass Sand Filter

5500 N.W.22 AVE. FT. LAUDERDALE, FL 33309

PHONE: 1-800-777-4255 * 1-954-484-8530